



INTRODUCTION TO FIBER OPTICS

A Communications Specialties, Inc. Education Guide

TABLE OF CONTENTS

| | |
|--|----|
| A Brief Introduction | 2 |
| <i>Advantages of Fiber Optic Systems</i> | 3 |
| Optical Transmitters | 5 |
| The Optical Fiber | 8 |
| <i>Launching the Light</i> | 8 |
| <i>Types of Optical Fiber</i> | 9 |
| <i>Losses in Optical Fiber</i> | 10 |
| <i>Optical Fiber Bandwidth</i> | 11 |
| <i>Fiber Optic Cable Construction</i> | 12 |
| <i>Other Types of Fibers</i> | 12 |
| <i>Optical Connectors</i> | 13 |
| <i>Optical Splices</i> | 14 |
| Optical Receivers | 15 |
| Designing a Fiber Optic System | 18 |
| System Design Check List | 19 |
| <i>Contact Information</i> | 20 |



A BRIEF INTRODUCTION

Our current “age of technology” is the result of many brilliant inventions and discoveries, but it is our ability to transmit information, and the media we use to do it, that is perhaps most responsible for its evolution. Progressing from the copper wire of a century ago to today’s fiber optic cable, our increasing ability to transmit more information, more quickly and over longer distances has expanded the boundaries of our technological development in all areas.

Today’s low-loss glass fiber optic cable offers almost unlimited bandwidth and unique advantages over all previously developed transmission media. The basic point-to-point fiber optic transmission system consists of three basic elements: the optical transmitter, the fiber optic cable and the optical receiver. (See Figure 1.)

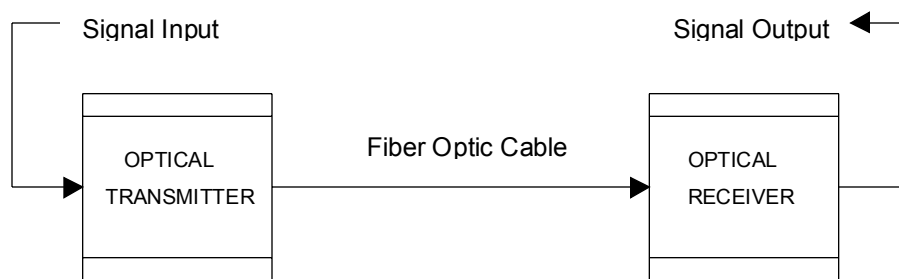

Figure 1. Basic Fiber Optic Transmission System

The Optical Transmitter: The transmitter converts an electrical analog or digital signal into a corresponding optical signal. The source of the optical signal can be either a light emitting diode, or a solid state laser diode. The most popular wavelengths of operation for optical transmitters are 850, 1300 or 1550 nanometers.

Most Math Fiber Optics™ transmission equipment manufactured by Communications Specialties operates at wavelengths of 850 or 1300nm.

The Fiber Optic Cable: The cable consists of one or more glass fibers, which act as waveguides for the optical signal. Fiber optic cable is similar to electrical cable in its construction, but provides special protection for the optical fiber within. For systems requiring transmission over distances of many kilometers, or where two or more fiber optic cables must be joined together, an optical splice is commonly used.

The Optical Receiver: The receiver converts the optical signal back into a replica of the original electrical signal. The detector of the optical signal is either a PIN-type photodiode or avalanche-type photodiode.

Most Math Fiber Optics™ receiving equipment uses PIN-type photodiodes.

Advantages of Fiber Optics Systems

Fiber optic transmission systems – a fiber optic transmitter and receiver, connected by fiber optic cable – offer a wide range of benefits not offered by traditional copper wire or coaxial cable. These include:

1. The ability to carry much more information and deliver it with greater fidelity than either copper wire or coaxial cable.
2. Fiber optic cable can support much higher data rates, and at greater distances, than coaxial cable, making it ideal for transmission of serial digital data.
3. The fiber is totally immune to virtually all kinds of interference, including lightning, and will not conduct electricity. It can therefore come in direct contact with high voltage electrical equipment and power lines. It will also not create ground loops of any kind.
4. As the basic fiber is made of glass, it will not corrode and is unaffected by most chemicals. It can be buried directly in most kinds of soil or exposed to most corrosive atmospheres in chemical plants without significant concern.
5. Since the only carrier in the fiber is light, there is no possibility of a spark from a broken fiber. Even in the most explosive of atmospheres, there is no fire hazard, and no danger of electrical shock to personnel repairing broken fibers.
6. Fiber optic cables are virtually unaffected by outdoor atmospheric conditions, allowing them to be lashed directly to telephone poles or existing electrical cables without concern for extraneous signal pickup.
7. A fiber optic cable, even one that contains many fibers, is usually much smaller and lighter in weight than a wire or coaxial cable with similar information carrying capacity. It is easier to handle and install, and uses less duct space. (It can frequently be installed without ducts.)
8. Fiber optic cable is ideal for secure communications systems because it is very difficult to tap but very easy to monitor. In addition, there is absolutely no electrical radiation from a fiber.

How are fiber optic cables able to provide all of these advantages? This guide will provide an overview of fiber optic technology – with sections devoted to each of the three system components – transmitters, receivers, and the fiber cable itself. An appreciation of the underlying technology will provide a useful framework for understanding the reasons behind its many benefits.

OPTICAL TRANSMITTERS

The basic optical transmitter converts electrical input signals into modulated light for transmission over an optical fiber. Depending on the nature of this signal, the resulting modulated light may be turned on and off or may be linearly varied in intensity between two predetermined levels. Figure 2 shows a graphic representation of these two basic schemes.

The most common devices used as the light source in optical transmitters are the *light emitting diode* (LED) and the *laser diode* (LD). In a fiber optic system, these devices are mounted in a package that enables an optical fiber to be placed in very close proximity to the light emitting region in order to couple as much light as possible into the fiber. In some cases, the emitter is even fitted with a tiny spherical lens to collect and focus “every last drop” of light onto the fiber and in other cases, a fiber is “pigtailed” directly onto the actual surface of the emitter.

LEDs have relatively large emitting areas and as a result are not as good light sources as LDs. However, they are widely used for short to moderate transmission distances because they

are much more economical, quite linear in terms of light output versus electrical current input and stable in terms of light output versus ambient operating temperature. LDs, on the other hand, have very small light emitting surfaces and can couple many times more power to the fiber than LEDs. LDs are also linear in terms of light output versus electrical current input, but unlike LEDs, they are not stable over wide operating temperature ranges and require more elaborate circuitry to achieve acceptable stability. In addition, their added cost makes them primarily useful for applications that require the transmission of signals over long distances.

LEDs and LDs operate in the infrared portion of the electromagnetic

spectrum so that their light output is usually invisible to the human eye. Their operating wavelengths are chosen to be compatible with the lowest transmission loss wavelengths of glass fibers and highest sensitivity ranges of photodiodes. The most common wavelengths in use today are 850 nanometers, 1300 nanometers, and 1550 nanometers. Both LEDs and LDs are available in all three wavelengths.

LEDs and LDs, as previously stated, are modulated in one of two ways; on and off, or linearly. Figure 3 shows simplified circuitry to achieve either method with an LED or LD. As can be seen from Figure 3A, a transistor is used to switch the LED or LD on and off in step with an input digital signal. This signal can be converted from almost any digital format by the appropriate circuitry, into the correct

base drive for the transistor. Overall speed is then determined by the circuitry and the inherent speed of the LED or LD. Used in this manner, speeds of several hundred megahertz are readily achieved for LEDs and thousands of megahertz for LDs. Temperature stabilization circuitry for the LD has been omitted from this example for simplicity. LEDs do not normally require any temperature stabilization.

Linear modulation of an LED or LD is accomplished by the operational amplifier circuit of figure 3B. The inverting input is used to supply the modulating drive to the LED or LD while the non-inverting input supplies a DC bias reference. Once again, temperature stabilization circuitry for the LD has been omitted from this example for simplicity.

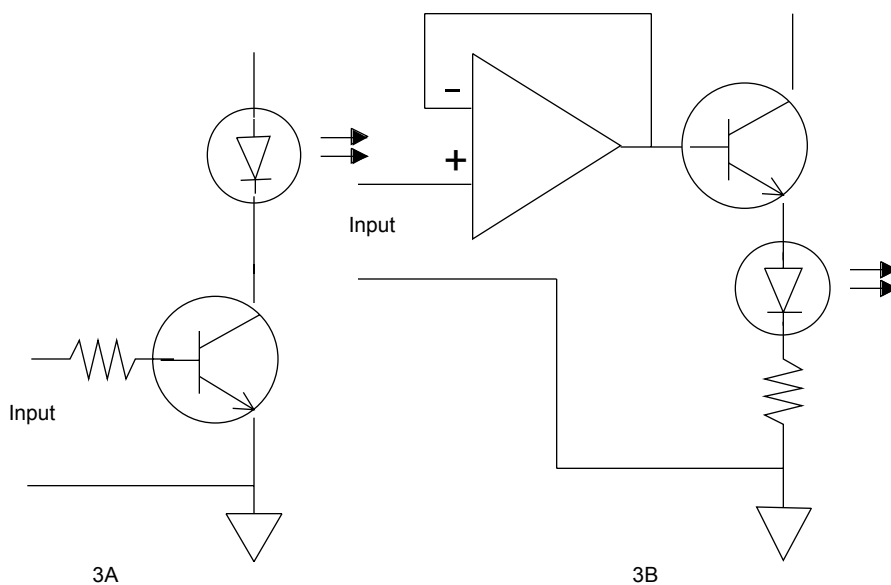

Figure 3. Methods of Modulating LEDs or Laser Diodes

Digital on/off modulation of an LED or LD can take a number of forms. The simplest, as we have already seen, is light-on for a logic “1”, and light-off for a logic “0”. Two other common forms are *pulse width modulation* and *pulse rate modulation*. In the former, a constant stream of pulses is produced with one width signifying a logic “1” and another width, a logic “0”. In the latter, the pulses are all of the same width but the pulse rate changes to differentiate between logic “1” and logic “0”.

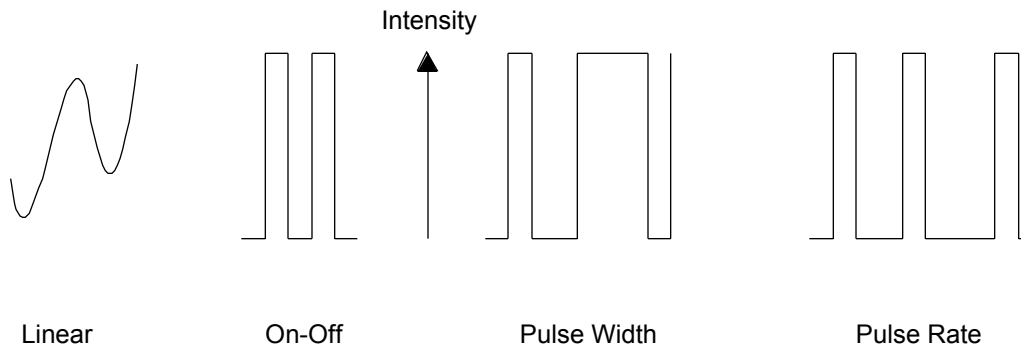

Figure 4. Various Methods to Optically Transmit Analog Information

Analog modulation can also take a number of forms. The simplest is intensity modulation where the brightness of an LED is varied in direct step with the variations of the transmitted signal. In other methods, an RF carrier is first frequency modulated with another signal or, in some cases, several RF carriers are separately modulated with separate signals, then all are combined and transmitted as one complex waveform.

Figure 4 shows all of the above modulation methods as a function of light output.

The equivalent operating frequency of light, which is, after all, electromagnetic radiation, is extremely high

– on the order of 1,000,000 GHz. The output bandwidth of the light produced by LEDs and Laser diodes is quite wide. Unfortunately, today’s technology does not allow this bandwidth to be selectively used in the way that conventional radio frequency transmissions are utilized. Rather, the entire optical bandwidth is turned on and off in the same way that early “spark transmitters” (in the infancy of radio), turned wide portions of the RF spectrum on and off. However, with time, researchers will overcome this obstacle and “coherent transmissions”, as they are called, will become the direction in which the fiber optic field progresses.

THE OPTICAL FIBER

Launching the Light

Once the transmitter has converted the electrical input signal into whatever form of modulated light is desired, the light must be “launched” into the optical fiber.

As previously mentioned, there are two methods whereby light is coupled into a fiber. One is by pigtailing. The other is by placing the fiber’s tip in very close proximity to an LED or LD.

When the proximity type of coupling is employed, the amount of light that will enter the fiber is a function of one of four factors: the intensity of the LED or LD, the area of the light emitting surface, the acceptance angle of the fiber, and the losses due to reflections and scattering. Following is a short discussion on each:

Intensity: The intensity of an LED or LD is a function of its design and is usually specified in terms of total power output at a particular drive current. Sometimes, this figure is given as actual power that is delivered into a particular type of fiber. All other factors being equal, more power provided by an LED or LD translates to more power “launched” into the fiber.

Area: The amount of light “launched” into a fiber is a function of the area of the light emitting surface compared to the area of the light accepting core of the fiber. The smaller this ratio is, the more light that is “launched” into the fiber.

Acceptance Angle: The acceptance angle of a fiber is expressed in terms of numeric aperture. The numerical aperture (NA) is defined as the sine of one half of the acceptance angle of the fiber. Typical NA values are 0.1 to 0.4 which correspond to acceptance angles of 11 degrees to 46 degrees. Optical fibers will only transmit light that enters at an angle that is equal to or less than the acceptance angle for the particular fiber.

Other Losses: Other than opaque obstructions on the surface of a fiber, there is always a loss due to reflection from the entrance and exit surface of any fiber. This loss is called the Fresnell Loss and is equal to about 4% for each transition between air and glass. There are special coupling gels that can be applied between glass surfaces to reduce this loss when necessary.

Types of Optical Fiber

There are two types of fiber constructions in use today: step index and graded index. As Figure 5 illustrates, light propagates through these different types of fiber in two different ways.

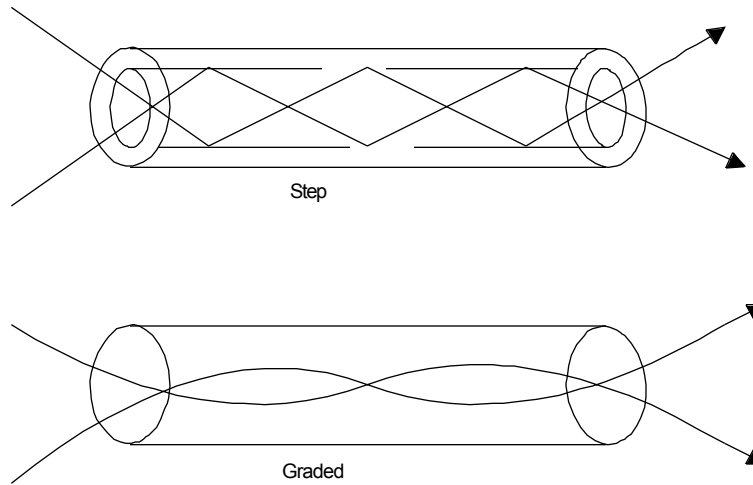

Figure 5, Light Propagation Through Step and Graded Index Fibers

As shown in the drawing, step index fiber consists of a core of low loss glass surrounded by a cladding of even lower refractive index glass. This difference in refractive index between the two types of glass causes light to continually “bounce” between the core/cladding interface along the entire length of the fiber. In graded index fiber, only one type of glass is used, but it is treated so that the index of refraction gradually decreases as the distance from the core increases. The result of this construction is that light continuously bends toward the center of the fiber much like a continuous lens.

Optical fiber is commonly characterized in terms of the core/cladding dimensions, which are given in microns. Currently, there are three popular sizes in general use although other sizes do exist for special applications. These are 50/125 and 62.5/125 multimode fiber and 8-10/125 single-mode fiber. The 50 and 62.5 micron core fibers are usually driven by LEDs, and most commonly used for short and medium length point-to-point transmission systems. The 8-10 micron core fiber is driven by a laser diode and is most often used for long distance telecommunications purposes.

Losses in Optical Fiber

Other than the losses exhibited when coupling LEDs or LDs into a fiber, there are losses that occur as the light travels through the actual fiber.

The core of an optical fiber is made of ultra-pure low-loss glass. Considering that light has to pass through thousands of feet or more of fiber core, the purity of the glass must be extremely high. To appreciate the purity of this glass, consider the glass in common windowpanes. We think of windowpanes as “clear,” allowing light to pass freely through, but this is because they are only $\frac{1}{16}$ to $\frac{1}{4}$ inch thick. In contrast to this clear appearance, the edges of a broken windowpane look green and almost opaque. In this case, the light is passing edge-wise into the glass, through several inches. Just imagine how little light would be able to pass through a thousand feet of window glass!

Most general purpose optical fiber exhibits losses of 4 to 6 dB per km (a 60% to 75% loss per km) at a wavelength of 850nm. When the wavelength is changed to 1300nm, the loss drops to about 3 to 4 dB (50% to 60%) per km. At 1550nm, it is even lower. Premium fibers are available with loss figures of 3 dB (50%) per km at 850nm and 1 dB (20%) per km at 1300nm. Losses of 0.5 dB (10%) per km at 1550 nm are not uncommon. These losses are primarily the result of random scattering of light and absorption by actual impurities within the glass.

Another source of loss within the fiber is due to excessive bending, which causes some of the light to leave the core area of the fiber. The smaller the bend radius, the greater the loss. Because of this, bends along a fiber optic cable should have a turning radius of at least an inch.

Optical Fiber Bandwidth

All of the above attenuation factors result in simple attenuation that is independent of bandwidth. In other words, a 3 dB loss means that 50% of the light will be lost whether it is being modulated at 10Hz or 100 MHz. There is an actual bandwidth limitation of optical fiber however, and this is measured in MHz per km. The easiest way to understand why this loss occurs is to refer to Figure 6 (next page).

As Figure 6 illustrates, a ray of light that enters a fiber relatively straight or at a slight angle (M1) has a shorter path through the fiber than light which enters at an angle close to the maximum acceptance angle (M2). As a result, different rays (or modes) of light reach the end of fiber at different times, even though the original source is the same LED or LD. This produces a “smearing” effect or uncertainty as to where the start and end of the pulse occurs at the output end of the fiber - which in turn limits the maximum frequency that can be transmitted. In short, the less modes, the higher the bandwidth of the fiber. The way that the

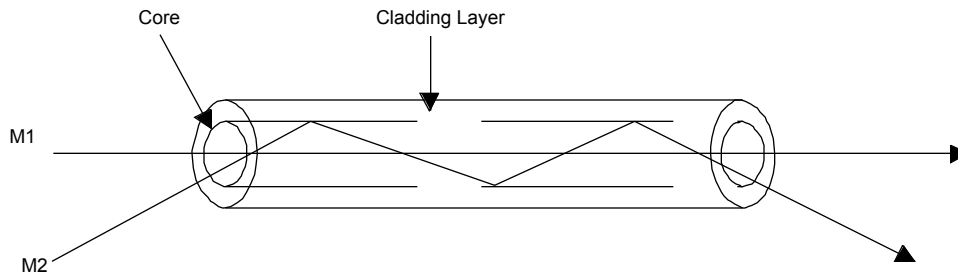

Figure 6, Different Light Path Lengths Determine the Bandwidth of a Fiber

number of modes is reduced is by making the core of the fiber as small as possible. Single-mode fiber, with a core measuring only 8 to 10 microns in diameter, has a much higher bandwidth because it allows only a few modes of light to propagate along its core. Fibers with a wider core diameter, such as 50 and 62.5 microns, allow many more modes to propagate and are therefore referred to as “multimode” fibers.

Typical bandwidth for common fibers range from a few MHz per km for very large core fibers, to hundreds of MHz per km for standard multimode fiber, to thousands of MHz per km for single-mode fibers. And as the length

of fiber increases, its bandwidth will decrease proportionally. For example, a fiber cable that can support 500 MHz bandwidth at a distance of one kilometer will only be able to support 250 MHz at 2 kilometers and 100 MHz at 5 kilometers.

Because single-mode fiber has such a high inherent bandwidth, the “bandwidth reduction as a function of length” factor is not a real issue of concern when using this type of fiber. However, it is a consideration when using multimode fiber, as its maximum bandwidth often falls within the range of the signals most often used in point-to-point transmission systems.

Fiber Optic Cable Construction

Fiber optic cable comes in all sizes and shapes. Like coaxial cable, its actual construction is a function of its intended application. It also has a similar “feel” and appearance. Figure 7 is a sketch of a typical fiber optic cable.

The basic optical fiber is provided with a buffer coating which is mainly used for protection during the manufacturing process. This fiber is then enclosed in a central PVC loose tube which allows the fiber to flex and bend, particularly when going around corners or when being pulled through conduits.

Around the loose tube is a braided Kevlar yarn strength member which absorbs most of the strain put on the fiber during installation. Finally, a PVC outer jacket seals the cable and prevents moisture from entering.

Basic optical fiber is ideal for most inter-building applications where extreme ruggedness is not required. In addition to the “basic” variety, it is also available for just about any application, including direct buried, armored, rodent resistant cable with steel outer jacket, and UL approved plenum grade cable. Color-coded, multi-fiber cable is also available.

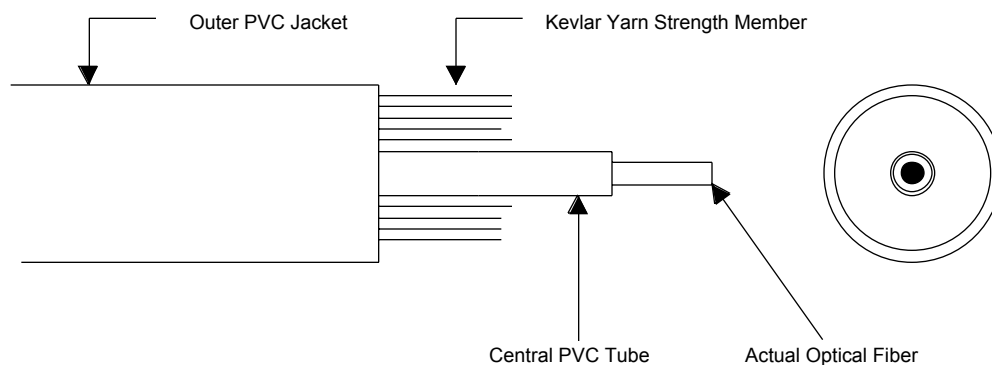

Figure 7, Construction of a Typical fiber Optic Cable

Other Types of Fibers

Two additional types of fiber – very large core diameter silica fiber and fiber made completely of plastic – are normally not employed for data transmission.

Silica fiber is typically used in applications involving high-power lasers and sensors, such as medical laser surgery.

All-plastic fiber is useful for very short data links within equipment because it may be used with relatively inexpensive LEDs. An isolation system for use as part of a high voltage power supply would be a typical example of an application for plastic fiber.

Optical Connectors

Optical connectors are the means by which fiber optic cable is usually connected to peripheral equipment and to other fibers. These connectors are similar to their electrical counterparts in function and outward appearance but are actually high precision devices. In operation, the connector centers the small fiber so that its light gathering core lies directly over and in line with the light source (or other

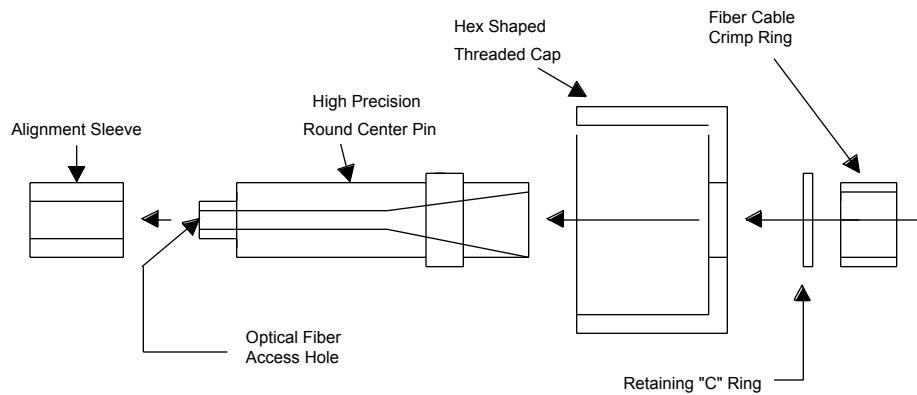

Figure 8, Construction of SMA Connector

fiber) to tolerances of a few ten thousandths of an inch. Since the core size of common 50 micron fiber is only 0.002 inches, the need for such extreme tolerances is obvious.

There are many different types of optical connectors in use today. The SMA connector, which was first developed before the invention of single-mode fiber, was the most popular type of connector until recently. Figure 8 shows an exploded view of the parts of this connector.

The most popular type of multimode connector in use today is the ST connector. Initially developed by AT&T

for telecommunications purposes, this connector uses a twist lock type of design and provides lower overall losses than the SMA. A typical mated pair of ST connectors will exhibit less than 1 dB (20%) of loss and does not require alignment sleeves or other similar devices. The inclusion of an "anti-rotation tab" assures that every time the connectors are mated, the fibers always return to the same rotational position assuring constant, uniform performance.

ST connectors are available for both multimode and single-mode fibers, the primary difference being the overall tolerances. Note that multimode ST

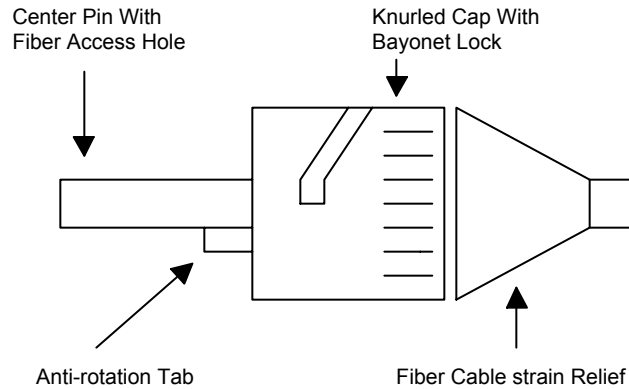

Figure 9, Major Features of the "Industry Standard" ST Connector

connectors will only perform properly with multimode fibers. More expensive single-mode ST connectors will perform properly with both single-mode and multimode fibers. The installation procedure for the ST connector is very similar to that of the SMA and requires approximately the same amount of time. Figure 9 shows some of the major features of the typical ST connector.

Optical Splices

While optical connectors can be used to connect fiber optic cables together, there are other methods that result in much lower loss splices. Two of the most common and popular are the mechanical splice and the fusion splice. Both are capable of splice losses in the range of 0.15 dB (3%) to 0.1 dB (2%).

In a mechanical splice, the ends of two pieces of fiber are cleaned and stripped, then carefully butted together and aligned using a mechanical assembly. A gel is used at the point of contact to reduce light reflection and keep the splice loss at a minimum. The ends

of the fiber are held together by friction or compression, and the splice assembly features a locking mechanism so that the fibers remained aligned.

A fusion splice, by contrast, involves actually melting (fusing) together the ends of two pieces of fiber. The result is a continuous fiber without a break. Fusion splices require special expensive splicing equipment but can be performed very quickly, so the cost becomes reasonable if done in quantity. As fusion splices are fragile, mechanical devices are usually employed to protect them.

OPTICAL RECEIVERS

The basic optical receiver converts the modulated light coming from the optical fiber back into a replica of the original signal applied to the transmitter.

The detector of this modulated light is usually a photodiode of either the PIN or the Avalanche type. This detector is mounted in a connector similar to the one used for the LED or LD. Photodiodes usually have a large sensitive detecting area that can be several hundred microns in diameter. This relaxes the need for special precautions in centering the fiber in the receiving connector and makes the “alignment” concern much less critical than it is in optical transmitters.

Since the amount of light that exits a fiber is quite small, optical receivers usually employ high gain internal amplifiers. Because of this, for any given system, it is important only to use the size fiber specified as appropriate. Otherwise, overloading of the optical receiver may occur. If, for example, a transmitter/receiver pair designed for use with single-mode fiber were used with multimode fiber, the large amount of light present at the output of the fiber (due to over-coupling at the light source) would overload the receiver and cause a severely distorted output signal. Similarly, if a transmitter/receiver pair designed for use with multimode fiber were used with single-mode fiber, not enough light would reach the receiver, resulting in either

an excessively noisy output signal or no signal at all. The only time any sort of receiver “mismatching” might be considered is when there is so much excessive loss in the fiber that the extra 5 to 15 dB of light coupled into a multimode fiber by a single-mode light source is the only chance to achieve proper operation. However, this is an extreme case and is not normally recommended.

As in the case of transmitters, optical receivers are available in both analog and digital versions. Both types usually employ an analog preamplifier stage, followed by either an analog or digital output stage (depending on the type of receiver).

Figure 10 (next page) is a functional diagram of a simple analog optical receiver. The first stage is an operational amplifier connected as a current-to-voltage converter.

This stage takes the tiny current from the photodiode and converts it into a voltage, usually in the millivolt range. The next stage is a simple operational voltage amplifier. Here the signal is raised to the desired output level.

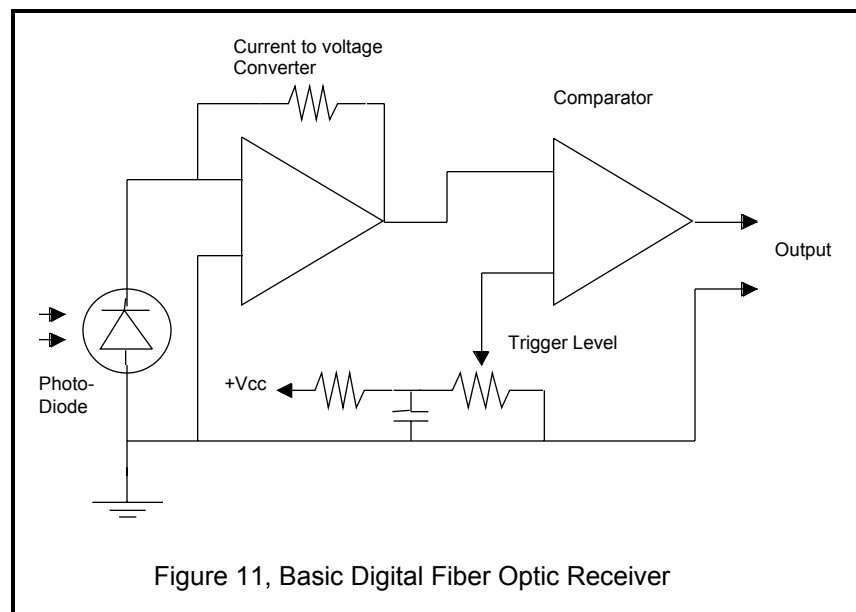
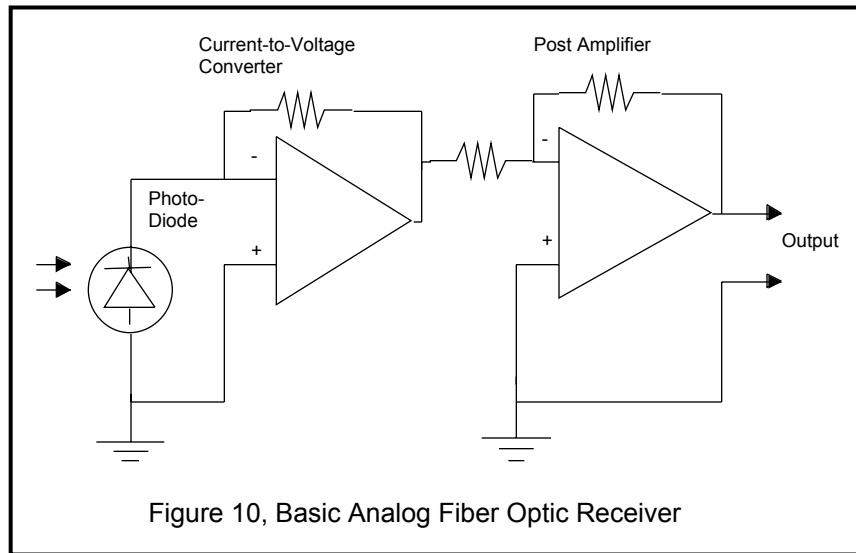

Figure 11 is a functional diagram of a simple digital optical receiver. As in the case of the analog receiver, the first stage is a current-to-voltage converter. The output of this stage, however, is fed to a voltage comparator, which produces a clean, fast rise-time digital output signal. The trigger level adjustment, when present, is used to “touch up” the point on the analog signal where the comparator switches. This allows the symmetry of the recovered digital signal to be trimmed as accurately as desired.

Additional stages are often added to both analog and digital receivers to provide drivers for coaxial cables, protocol converters or a host of other functions in efforts to reproduce the original signal as accurately as possible. It is important to note that while fiber optic cable is immune to all forms of interference, the electronic receiver is not. Because of this, normal precautions, such as shielding and grounding, should be taken when using fiber optic electronic components.

DESIGNING A FIBER OPTIC SYSTEM

When designing a fiber optic system, there are many factors that must be considered – all of which contribute to the final goal of ensuring that enough light reaches the receiver. Without the right amount of light, the entire system will not operate properly. Figure 12 identifies many of these factors and considerations.

The following step-by-step procedure should be followed when designing any system.

1. Determine the correct optical transmitter and receiver combination based upon the signal to be transmitted (Analog, Digital, Audio, Video, RS-232, RS-422, RS-485, etc.).
2. Determine the operating power available (AC, DC, etc.).
3. Determine the special modifications (if any) necessary (such as impedances, bandwidths, special connectors, special fiber size, etc.).
4. Calculate the total optical loss (in dB) in the system by adding the cable loss, splice loss, and connector loss. These parameters should be available from the manufacturer of the electronics and fiber.
5. Compare the loss figure obtained with the allowable optical loss budget of the receiver. Be certain to add a safety margin factor of at least 3 dB to the entire system.
6. Check that the fiber bandwidth is adequate to pass the signal desired.

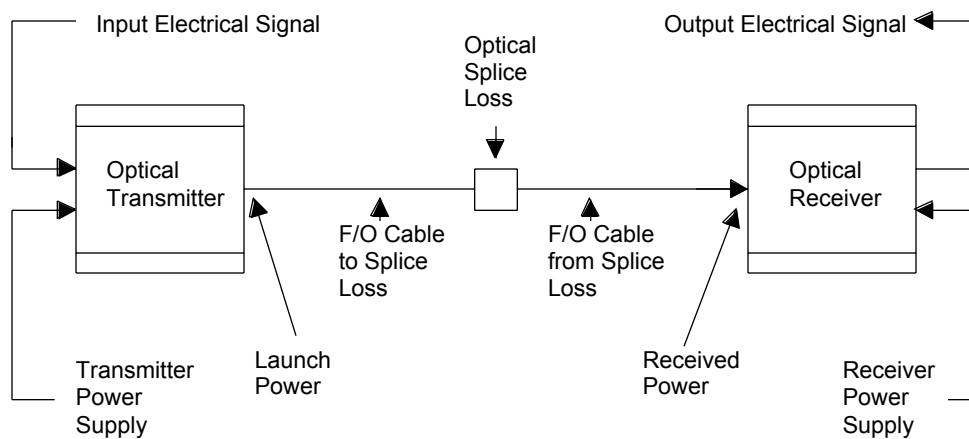

Figure 12, Important Parameters to Consider When Specifying F/O Systems

If the above calculations show that the fiber bandwidth you plan to use is inadequate for transmitting the required signal the necessary distance, it will be necessary either to select a different transmitter/receiver (wavelength) combination, or consider the use of a lower loss premium fiber.

SYSTEM DESIGN CHECKLIST

Application (Brief description of intended use):

Analog Signal Parameters:

| | |
|--------------------|--|
| Input Voltage | |
| Input Impedance | |
| Output Voltage | |
| Output Impedance | |
| Signal/Noise Ratio | |
| DC or AC Coupling | |
| Bandwidth | |
| Signal Connectors | |
| Other Details: | |

Digital Signal Parameters:

| | |
|--------------------------------------|--|
| Compatibility (RS-232, 422, 485 etc) | |
| Data Rate | |
| DC or AC Coupling | |
| Bit Error Rate | |
| Signal Connectors | |
| Other Details | |

Power Supply Requirements:

| | |
|-------------------|--|
| Voltage Available | |
| Current Available | |
| AC, DC | |
| Power Connectors | |
| Other Details | |

Fiber Optic Requirements:

Transmission Distance

Optical Wavelength

Required Loss Budget

Optical Connectors

Fiber Type

Fiber Length

Installation Environment

General Requirements:

Housing Size

Mounting Method

Environment

Operating Temperature Range

Storage Temperature Range

Other Details

Additional Comments:

CONTACT COMMUNICATIONS SPECIALTIES

We hope this guide has helped you to better understand the basics of a fiber optic technology system design. The specification check sheet on the preceding pages can be used to help collect and organize the necessary information when actually designing a system.

Remember, if you ever have any questions about how to proceed, please contact Communications Specialties at (516) 273-0404 for additional guidance, you may contact us via email at info@commspecial.com or visit our web site: www.commspecial.com.



55 Cabot Court Hauppauge, NY 11788
Phone: (516) 273-0404
Fax: (516) 273-1638

Singapore Representative Office:
7500A Beach Road
#15-314 The Plaza
Singapore 199591
Phone: +65 293 0258
Fax: +65 293 1538

<http://www.commspecial.com>
info@commspecial.com

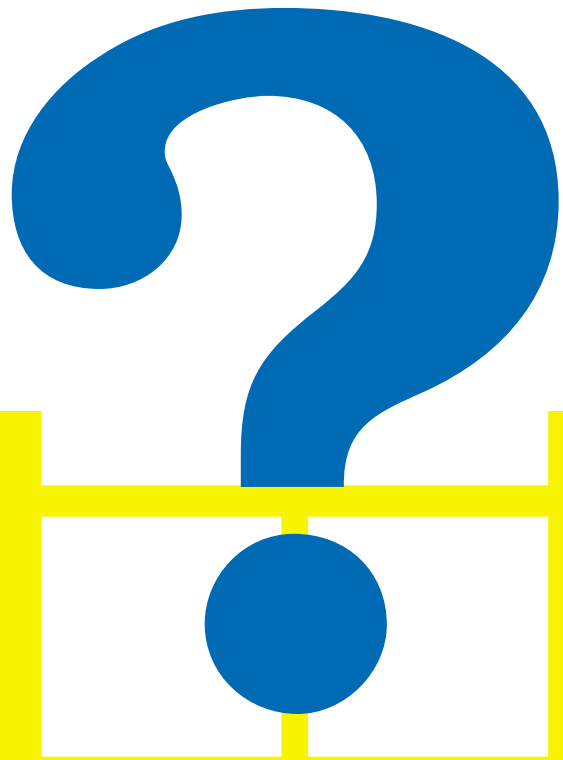

**INTRODUCTION TO
FIBER OPTIC CABLES
& CONNECTORS**

INTRODUCTION

In the design of a fiber optic transmission system, the first step is to determine which transmitters and receivers are best suited to the signal type.

The best way to find the right system is to compare data sheets and consult with sales engineers to find which products best meet the system specifications.

Once this is done, the next consideration is the choice of the fiber optic cable itself, the optical connectors to be used and the method of attaching these connectors.

This portion of the system design is not so straightforward and is shrouded in a great deal of misunderstandings and fear of complex “glass grinding” techniques by the inexperienced. This booklet should clarify several misconceptions about fiber cable and termination.

CABLE CONSTRUCTION

Like copper wire, fiber optic cable is available in many physical variations. There are single and multiple conductor constructions, aerial and direct burial styles, plenum and riser cables and even ultra-rugged military type tactical cables that will withstand severe mechanical abuse. Which cable one chooses is, of course, dependent upon the application.

Regardless of the final outer construction however, all fiber optic cable contains one or more optical fibers. These fibers are protected by an internal construction that is unique to fiber optic cable. The two most common protection schemes in use today are to enclose the tiny fiber in a loose fitting tube or to coat the fiber with a tight fitting buffer coating.

In the loose tube method the fiber is enclosed in a plastic buffer-tube that is larger in inner diameter than the outer diameter of the fiber itself. This tube is sometimes filled with a silicone gel to prevent the buildup of

moisture as well. Since the fiber is basically free to “float” within the tube, mechanical forces acting on the outside of the cable do not usually reach the fiber.

Cable containing loose buffer-tube fiber is generally very tolerant of axial forces of the type encountered when pulling through conduits or where constant mechanical stress is present such as cables employed for aerial use. Since the fiber is not under any significant strain, loose buffer-tube cables exhibit low optical attenuation losses.

In the tight buffer construction, a thick coating of a plastic-type material is applied directly to the outside of the fiber itself. This results in a smaller overall diameter of the entire cable and one that is more resistant to crushing or overall impact-type forces. Because the fiber is not free to “float” however, tensile strength is not as great. Tight buffer cable is normally lighter in weight and more flexible than loose-tube cable and is usually employed for less severe applications such as within a building or to interconnect individual pieces of equipment. *Figure 1 is a diagram of the basic construction of both loose-tube and tight-buffer fiber optic cable.*

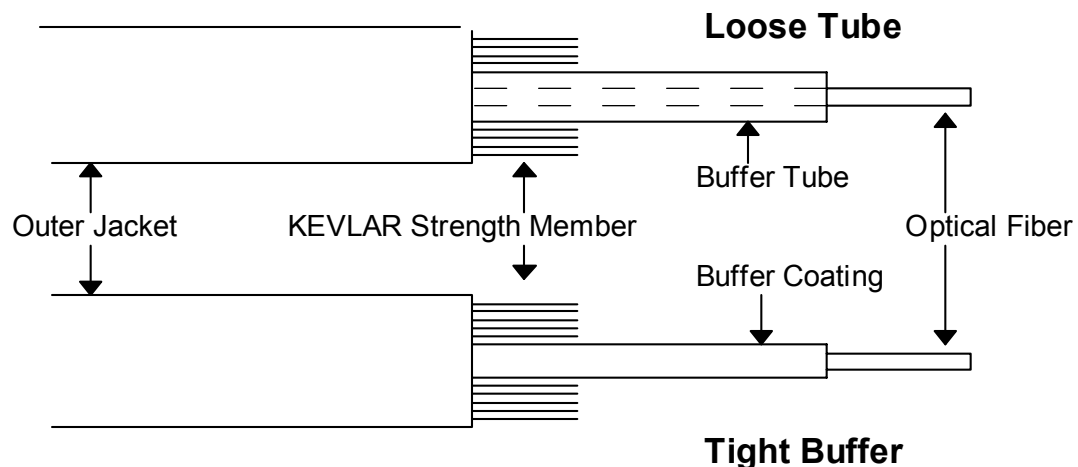

Figure 1, Basic Fiber Optic Cable Construction

Figure 2 is a drawing of the cross section details of a single and a two conductor fiber optic cable as well as a more complex multi-fiber cable. Note that the two conductor cable is similar to the common AC power line electrical cable.

As can be seen from the diagram, in all cases the fiber/buffer tube is first enclosed in a layer of synthetic yarn such as Kevlar for strength. An outer jacket of PVC or similar material is then extruded over everything to protect the inside of the cable from the rigors of the operating environment. In multi-fiber cables, an additional strength member is also often added. While most fiber optic cables are manufactured of totally non-conductive materials, there are some cable that employ steel tape-wound outer jackets for rodent resistance (direct burial types) or metallic strength members such as steel wire for aerial (telephone pole) use. There are even fiber optic cables with imbedded copper electrical conductors for transferring power to remote electronic packages.

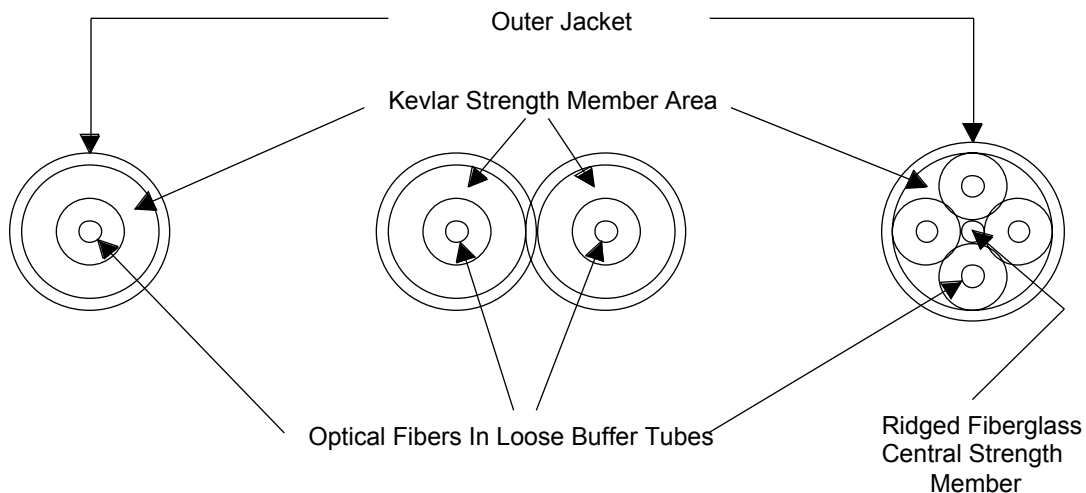

Figure 2, Cross Section Of Various Types Of Fiber Optic Cable

OPTICAL FIBER

Whether loose-buffer or tight-buffer, the actual glass fiber used in any fiber optic cable only comes in one of two basic types, multimode fiber for use over short to moderate transmission distances (up to about 10 Km) and single-mode fiber for use over distances that are generally greater than 10 Km. Communications grade multimode fiber normally comes in two sizes, 50 micron core and 62.5 micron core, the latter being the size most commonly available. The outer diameter of both is 125 microns and both use the same connector size. Single-mode fiber comes in only one size, 8-10 microns for the core diameter and 125 microns for the outer diameter. Connectors for single-mode fiber are not the same as those designed for multimode fiber but can look the same as we will soon discuss.

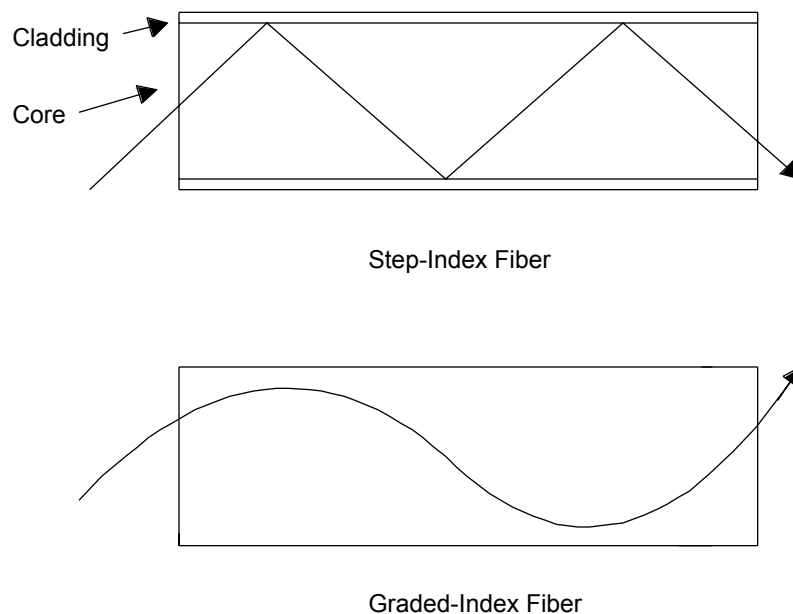

Figure 3, Light Path Through Step And Graded-Index Fiber

Figure 3 is a drawing of the construction of two types of optical fiber, step index and graded index.

Step index fiber has a core of ultra-pure glass surrounded by a cladding layer of standard glass with a higher refractive index. This causes light traveling within the fiber to continually “bounce” between the walls of the core much like a ball bouncing through a pipe. Graded index fiber on the other hand operates by refracting (or bending) light continually toward the center of the fiber like a long lens. In a graded index fiber the entire fiber is made of ultra-pure glass. In both types of fiber however, the light is effectively trapped and does not normally exit except at the far end.

Losses in an optical fiber are the result of absorption and impurities within the glass as well as mechanical strains that bend the fiber at an angle that is so sharp that light is actually able to “leak out” through the cladding region. Losses are also dependent on the wavelength of the light employed in a system since the degree of light absorption by glass varies for different wavelengths. At 850 nanometers, the wavelength most commonly used in short-range transmission systems, typical fiber has a loss of 4 to 5 dB per kilometer of length. At 1300 nanometers this loss drops to under 3 dB per kilometer and at 1550 nanometers, the loss is a dB or so. The last two wavelengths are therefore obviously used for longer transmission distances.

The losses described above are independent of the frequency or data rate of the signals being transmitted. There is another loss factor however that is frequency (and wavelength) related and is due to the fact that light can have many paths through the fiber. Figure 4 shows the mechanism of this loss through step-index fiber.

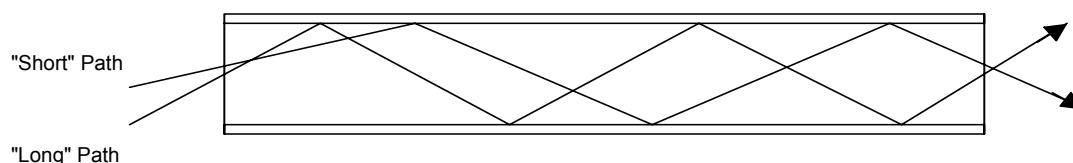

Figure 4, Various Light Path Lengths Through A Fiber

A light path straighter through a fiber is shorter than a light path with maximum “bouncing”. This means that for a fast rise-time pulse of light, some paths will result in light reaching the end of the fiber sooner than through other paths. This causes a smearing or spreading effect on the output rise-time of the light pulse which limits the maximum speed of light changes that the fiber will allow. Since data is usually transmitted by pulses of light, this in essence limits the maximum data rate of the fiber. The spreading effect for a fiber is expressed in terms of MHz per kilometer. Standard 62.5 micron core multimode fiber usually has a bandwidth limitation of 160 MHz per kilometer at 850 nanometers and 500 MHz per kilometer at 1300 nanometers due to its large core size compared to the wavelength of the propagated light. Single mode fiber, because of its very small 8 micron core diameter has a bandwidth of thousands of MHz per kilometer at 1300 nanometers. For most low frequency applications however, the loss of light due to absorption will limit the transmission distance rather than the pulse spreading effect.

OPTICAL CONNECTORS ---

Since the tiny core of an optical fiber is what transmits the actual light, it is imperative that the fiber be properly aligned with emitters in transmitters, photo-detectors in receivers and adjacent fibers in splices. This is the function of the optical connector. Because of the small sizes of fibers, the optical connector is usually a high precision device with tolerances on the order of fractions of a thousandth of an inch.

Although there are many different styles available the most common optical cable connector in current use is the ST type shown in figure 5. The connector consists of a precision pin that houses the actual fiber, a spring-loaded mechanism that presses the pin against a similar pin in a mating connector (or electro-optic device) and a method of securing and strain-relieving the outer jacket of the fiber optic cable. ST connectors are available for both multimode and single-mode fibers. The main difference between the two is the precision of the central pin. Since this

difference is not readily noticeable, care must be taken to use the correct connector. While single-mode connectors will work properly with multimode emitters and detectors, connectors intended for use with multimode fiber such as the ST type will not work well (or at all) in a single-mode system.

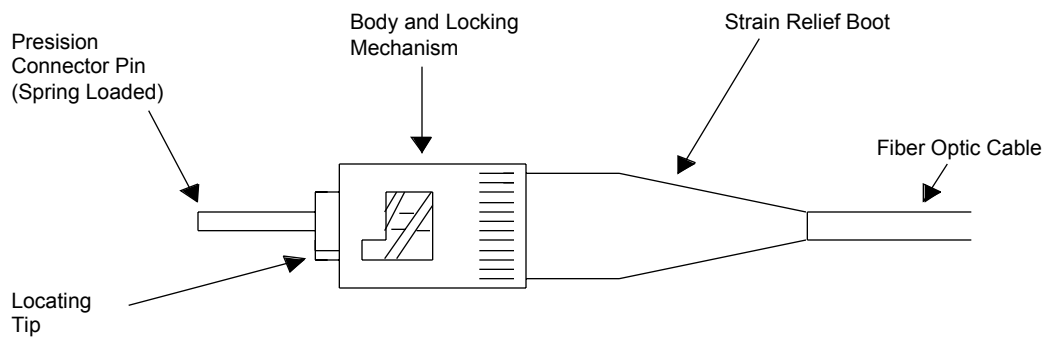

Figure 5, The ST-style Optical Connector

The traditional method for attaching optical connectors consists of first stripping the jacket from the fiber cable with tools that are almost exact equivalents of those used for electrical cable. Once this is done the strength members are trimmed and inserted into various restraining grommets or sleeves. For loose-tube fibers, the buffer tube is then removed exposing the actual fiber. For tight-buffer fibers, the buffer coating is removed with a precision stripping tool that looks like a small wire stripper. The process, up to this point is still similar to preparing copper wire. It is when the bare fiber is exposed that the differences (compared to copper wire) occur. The stripped fiber is now coated with a quick drying epoxy resin and inserted into a precision hole or groove in the connector pin. Then the strain relieving components are assembled and the basic connector is ready for finishing. At this point the end of the bare fiber is protruding from the front of the connector pin. The pin is placed in a special tool that is then used to cleave or cut the tiny glass

fiber flush with the end of the pin. This takes a second or two. Next the connector is placed into a small jig and run over two or three grades of fine lapping film, the equivalent of ultra-fine sandpaper. This completes the polishing of the fiber and the optical connector is ready for use. The complete task, not including the 5 minutes of epoxy drying time, takes anywhere from 5 to 10 minutes per connector depending on the skill level of the person.

Many people have reservations about “connectorizing” fiber optic cable due to problems they have heard about concerning the “grinding and polishing of glass”. When one realizes that the “grinding and polishing” takes less than a minute, and is done within a simple foolproof fixture, the mystery quickly evaporates. In fact, assembling an ST style optical connector is, in reality no more demanding a task than assembling an older style electrical BNC. Once one is completely familiar with the process, (which takes from 30 minutes to an hour to learn) the longest time interval involved in the finishing process is waiting for the epoxy to cure. Never-the-less the reservations continue. As a result, several connector manufacturers manufacture so-called “quick-crimp” optical connectors. These devices are installed with various mechanical clamp arrangements and hot melt or instant bond adhesives (or, in some cases no chemical adhesive at all). Some of these connectors are even provided with a pre-polished length of optical fiber in the tip thereby eliminating the finishing step altogether. Although these are a bit easier to install, the original “epoxy-polish” method is really not one that anyone should fear. *Figure 6 shows the various steps involved in installing conventional ST connectors.*

Other optical connectors that are available such as the SMA, SC and FCPC are similar in principle in that they position the fiber in a close tolerance tip which then mates with an equally precise device on the other end. They really only differ from each other in the mechanical way that that connectors mate to each other. In any event all optical connector manufacturers provide detailed, easy to follow step-by-step installation procedures for their respective connectors.

- 1. Slide boot and crimp tube over end of fiber

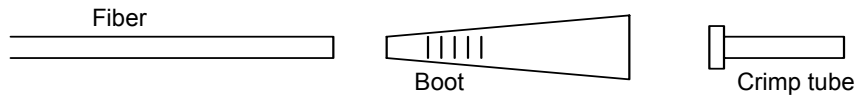

- 2. Strip fiber optic cable to dimensions shown

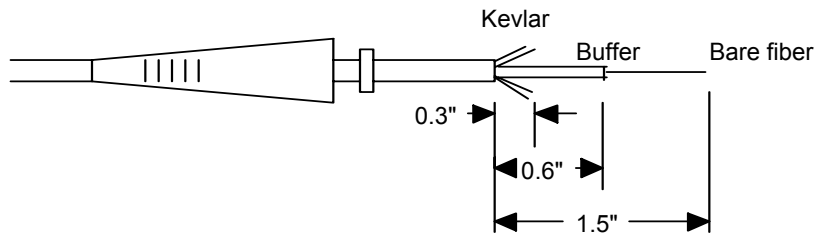

- 3. Cleave and apply epoxy

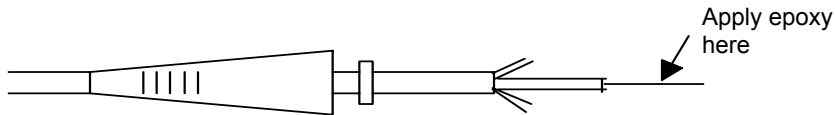

- 4. Assembly and crimp

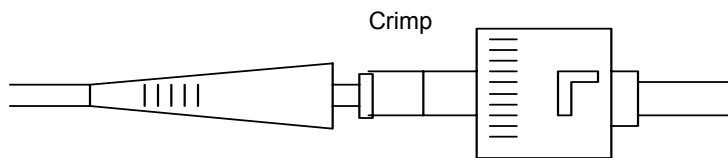

- 5. Complete connector

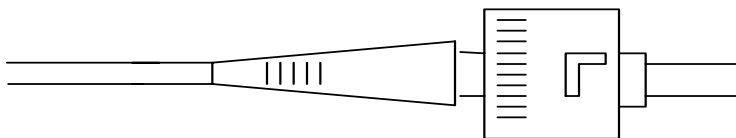

Figure 6, Typical Steps to Assemble a Connector on a fiber Optic Cable

